



**Tender Document
For
Body Building of Mobile Processing Unit on
Truck Chassis**

CSIR-Central Food Technological Research Institute

Mysore- 570 020, Karnataka-India

Tel #: 00 91 821 2515440/5447

Email: cosp@cftri.res.in/spo@cftri.res.in/sosp@cftri.res.in

Website: www.cftri.res.in



CSIR-Central Food Technological Research Institute
 Mysore- 570 020, Karnataka-India
 Tel #: 00 91 821 2515440/5447
 Email: cosp@cftri.res.in
 Website: www.cftri.res.in

Invitation for e-Bids / Notice Inviting e-Tender

CSIR- Central Food Technological Research Institute, Mysore, India is one of the premier institute under the aegis of Council of Scientific and Industrial Research, an autonomous body of Department of Scientific and Industrial Research (Government of India), New Delhi. CSIR-CFTRI is a Science and Knowledge based Research & Development (R&D) Organization. It is internationally known for its excellence in Scientific Research in Food Science & Technology.

The Director, CSIR-CFTRI invites e-bids from the Fabricators/Manufacturers and their distributors if any, for the procurement of the following Goods/Services for its day-to-day Research & Development (R&D). The Technical specifications, allied requirements and scope of supply are given in Chapter 4 appended here with.

Sr. No.	Tender No.	Brief Description of item(s)	Quantity	Type of Bid	Mode of Procurement
1	CFTRI/82417/2023	Body Building of Mobile Processing Unit on Truck Chassis	1 Unit	Single Stage Two Bid	Open Tender

1. E-Bids are invited through the electronic tendering process and the Tender Document can be downloaded from the e-Tender Central Public Procurement Portal (CPPP) of Government of India, <https://etenders.gov.in>. The submission of e-Bids will be only through the e-Tender portal <https://etenders.gov.in>. Bids will not be accepted in any other form.

2. Interested Bidders may obtain further information from the office of:

Controller of Stores & Purchase
 Central Food Technological Research Institute
 Mysore- 570 020, Karnataka-India
 Tel #: 00 91 821 2515440/5447
 Email: cosp@cftri.res.in
 Website: www.cftri.res.in

3. The prospective bidders should adhere to deadlines specified in Tender corresponding to this Tender on e-Tender portal <https://etenders.gov.in>.

4. (a) A Pre-Bid Conference (PBC) will be held as mentioned below

	Date	Time in hours (IST)	Venue
Pre-Bid Conference	Pre Bid Conference is scheduled on 18-OCT-2023 at 03.30 PM at CSIR-CFTRI, Mysore (By person/Online)		

Bidders desirous of attending Pre-bid meeting are required to provide the following details: -

1. Prospective Bidders Name & address
2. Name, designation & mobile number of the representative (s) attending the meeting.
3. E-mail ID to which the meeting invitation to be sent.
4. Pre-bid queries, if any.

The above information should be sent by e-mail to cosp@cftri.res.in / spo@cftri.res.in / sosp@cftri.res.in on or before 2.00pm of

(b) No Queries, suggestions or representation made after the PBC will be entertained. Changes incorporated to the bidding document subsequent to PBC shall be treated as amendment to the bidding document and will be hosted in the CPP Portal/CFTRI Website www.cftri.res.in

(c) The Prospective bidders are requested to take cognizance of the amendments if any, prior to submission of the bid which will be hosted on CSIR-CFTRI Website and CPP Portal before formulating and submitting the bids.

5. The Bid prepared by the Bidder shall include the following:

Bid Security (BS) / Earnest Money Deposit (EMD)	
a)	Bid Security/EMD is <u>NIL</u> if the Bidder is claiming exemption as per provisions specified in the Tender document. The bidder may furnish/submit BID SECURING DECLARATION as per FORMAT specified in Chapter-8, Annexure-B in lieu of EMD/Bid Security The Bid Security Declaration in the name of "The Director, CSIR-Central Food Research Institute, Mysore" to be part of the Technical Bid, without which the bid shall be rejected.
b)	For further details on the above, refer Tender document.
c)	Forms as specified in Chapter No.8

6. The Schedule for Submission of e-Bids and Opening of e-Bids is as follows:

Last Date & Time of Submission of e-Bid		Date and Time of Opening of e-Bid	
Date	Time (IST)	Date	Time (IST)
30-10-2023	2.00PM	31-10-2023	2.30PM

7. (a) In case of agents quoting in offshore procurements, on behalf of their principal manufacturers abroad, one agent cannot represent two manufacturers or quote on their behalf in a particular tender enquiry. One manufacturer can also authorize only one agent/ dealer. There can be only one bid from the following:

i)	The Principal manufacturer directly or through one Indian agent on their behalf; and
ii)	Indian/foreign agent on behalf of only one principal.

(b) Foreign Bidders must disclose the name and address of Indian agent and representative in India and Indian bidder must disclose their foreign principal or associates.

(c) If bidder is Indian Agent of Foreign Principal, the following instruction shall be complied and as amended from time to time as on the date of issue of Tender:

i)	The Bidder shall comply with restrictions under Rule 144(xi) of the GFR 2017 related to restrictions on participation of Foreign Bidders and their Authorised Indian Agent/Dealer in terms of Order No.P-45021/112/2020-PP(BE-II) (E-43780) dated 24-Aug-2020 of the Ministry of Commerce and Industry, Department for Promotion of Industry and Internal Trade, as amended from time to time as on the date of issue of Order.
----	---

8. A. CSIR-CFTRI is a Public Funded Research Institute under Department of Scientific & Industrial Research, Government of India and concessional Custom duty @ 0/5.15% is applicable for the goods purchased for Research purpose vide Government of India vide Notification No.51/96-Customs dated 23-July-1996, as amended from time to time.

B. CSIR-CFTRI is not eligible to issue any GST concessional rate certificate. GST @ prevailing rate is applicable. Hence, bidder may submit their bid accordingly.

9. The bids failing to comply the following clauses will be summarily rejected.

- (a) The bidders proposing to supply finished products directly/indirectly from Bidders of Countries sharing the land border with India should submit copy of registration with the Ministry of Home Affairs and Ministry of External Affairs.
 - (b) If the products supplied are not from Bidders of Countries sharing Land border with India, the Bidder should enclose a declaration
 - (c) The debarment of a Bidder/Vendor in this tender, if any, is reciprocal of that Principal's Country, if it is Import.
10. Bidders are requested to refer CSIR-CFTRI website www.cftri.res.in for Other General Tender's Terms and Condition which are also an integral part of this tender. [Path: Home Page → Tender → Standard Tender Document (Scrolling Text)]
11. The Director, CSIR-CFTRI, Mysore India reserves the right to accept or reject any bid or accept all bids either in part or in full or to split the order, or to annul the bidding process without assigning any reasons thereof.

Stores & Purchase Officer
For and on behalf of CSIR

General Instructions to Bidders: -

01. For participation in e-procurement all bidders (including Foreign bidders) need to enroll themselves on the CPP Portal (<https://www.etenders.gov.in>). Only enrolled/registered bidders with the said portal shall be allowed to participate in the e-tendering process.
02. Tender Documents may be downloaded from Central Public Procurement Portal <https://www.etenders.gov.in>. Aspiring Bidders who have not enrolled/ registered in e-procurement should enroll/ register before participating through the website <https://www.etenders.gov.in>. The portal enrolment is free of cost. Bidders are advised to go through instructions provided at 'Instructions for online Bid Submission'.
03. Tenderers can access tender documents on the website (For searching in the NIC site <https://www.etenders.gov.in>, kindly go to Tender Search option, select tender type and select ' Council of Scientific and Industrial Research' in organization tab and select CFTRI-Mysore-CSIR' in department type. Thereafter, Click on "Search" button to view all CSIR-CFTRI, Mysore tenders). Select the appropriate tender and fill them with all relevant information and submit the completed tender document online on the website <https://www/etenders.gov.in> as per the schedule. The tender document is available on website www.cftri.res.in also.
04. The Bidders should have Java 8 update 231 version-32 bit for uploading the bid in the CPP Portal.
05. CSIR-CFTRI neither operates nor manages the CPP Portal where online bids are submitted and therefore will not be responsible for any technical issues related to bid submission (viz., not being able to upload bid, blank/missing/part documents etc.,). If bid is incomplete on account of these, it will be treated as such and evaluated further. For any technical queries/issues related to online bid submission, Bidders must directly approach support service of CPP Portal as per the details given on their website.

INDEX

Chapter	Content	Chapter
1	Instructions to Bidders	1
2	General and Special Conditions of Contract	2
3	Schedule of Requirement	3
4	Specifications and Allied Technical Details	4
5	Price Schedule Forms	5
6	Qualification Requirements	6
7	Contract Form	7
8	Other Forms	8
9	Check List	9

CHAPTER - 1

INSTRUCTIONS TO BIDDERS

For details kindly refer Standard Tender Documents uploaded at CSIR-CFTRI website i.e. www.cftri.res.in →Tender

CHAPTER 2

CONDITIONS OF CONTRACT

A. GENERAL CONDITIONS OF CONTRACT (GCC)

Note: The General Conditions of Contract shall form the part of Purchase Order / Contract.

For details kindly refer Standard Tender Documents uploaded at CSIR-CFTRI website i.e. www.cftri.res.in →Tender

B. SPECIAL CONDITIONS OF CONTRACT (SCC)

The following Special Conditions of Contract (SCC) shall supplement and / or amend the General Conditions of Contract (GCC). Whenever there is a conflict, the provisions herein shall prevail over those in the GCC.

Sl.No.	GCC Clause Ref	Condition
1	GCC 2.1.1(l)	The Purchaser is: The Director CSIR-Central Food Technological Research Institute Mysore- 570 020, Karnataka-India Tel #: 00 91 821 2515440/5447 Email: cosp@cftri.res.in Website: www.cftri.res.in
2	GCC 2.1.1(m)	The Final Destination is: North East Centre for Technology Application and Reach (NECTAR) Survey of India Campus, Bonnie Brae Estate, Barik Point, Shilong, Meghalaya-793001
3	GCC 2.13.1	Performance Security : N.A The amount of the Performance Bank Guarantee shall be 10% of the contract value to be submitted within 21 days from the date of PO/order acceptance valid up to 60 days after the date of completion of performance obligations including warranty obligations.
4	GCC 2.16.3	Delivery - Mode of Transportation/ Shipment a) The mode of transportation shall be by Road. b) DELIVERY TERM: FOR NECTAR-Shilong, Meghalaya for Indigenous supply. c) Delivery period 12 weeks from the date of acceptance of Purchase Order

5	GCC 2.17.1	<p>Insurance</p> <p>The Insurance shall be for an amount equal to 110% of the invoice value of the contract from “warehouse to warehouse (final destination)” on “all risk basis” including strikes, riots and civil commotion till completion of installation and commissioning.</p>
6	GCC 2.21.3	<p>The period of validity of the Warranty for this tender shall be as below:</p> <p>Standard Warranty or minimum 2 years starting from date of satisfactory, and acceptance of the equipment</p>
7	GCC 2.22.1	<p>Payment Terms</p> <p>The method and conditions of payment to be made to the Supplier under this Contract shall be as follows:</p>
		<p>Payment for Goods and Services supplied from within India</p>
		<p>(a) 100% bill basis on Fabrication, and acceptance by the end user.</p>
		<p>(b) E-Payment: All payments, CSIR-CFTRI prefers to make Electronic Transfers (NEFT/RTGS) through scheduled bank</p>
		<p>(c) All payments due under the Contract shall be paid after deduction of statutory levies at source (like TDS, Income Tax, TCS etc.), wherever applicable.</p>
8	GCC 2.27.1	<p>Liquidated Damages (LD)/Penalty</p>
		<p>(a) As time is the essence of the contract, Delivery period mentioned in the Purchase Order should be strictly adhered to, otherwise will have to forfeit the EMD/PS and also LD clause will be applicable / enforced.</p>
		<p>(b) If the Supplier fails to Supply, Install and Commission the system as per specifications mentioned in the order within the due date, the Supplier is liable to pay LD/penalty of 0.5% of order value per week of delay in supply/installation subject to maximum of 10% beyond the due date. Such money will be deducted from any amount due or which may become due to the Supplier</p>
		<p>(c) CSIR-CFTRI reserves the right to cancel the Purchase Order in case the delay in supply is more than 10 weeks. Penalties, if any, will be deducted from the EMD/PS</p>
		<p>(d) The maximum amount of penalty shall be 10%</p>
		<p>(e) The LD/Penalty shall be levied on the delivered price of the delayed Goods or unperformed Services or Contract Value.</p>
9	GCC 2.34.1	<p>Applicable Law / Jurisdiction</p> <p>The place of jurisdiction is Mysore, India.</p>
10	GCC 2.35.1	<p>For notices, the Purchaser's address is The Director Attention: The Controller of Stores & Purchase CSIR-Central Food Technological Research Institute Mysore- 570 020, Karnataka-India Tel #: 00 91 821 2515440/5447 Email: cosp@cftri.res.in</p>

CHAPTER 3

(To be filled by the bidder and enclosed with the Technical Bid)

SCHEDULE OF REQUIREMENT

The Schedule of Requirement must clearly specify the time frame required (Schedule) for delivery of goods and services to be completed by the bidder (in reference to Scope of Supply given in Clause-4.2 of Chapter-4) if the Contract is awarded for the offer / proposal submitted by the bidder in response to this Tender.

A) Delivery Schedule:

Sr. No.	Brief Description of Goods and Services	Quantity & Unit	Delivery Schedule
1	Body Building of Mobile Processing Unit on Truck Chassis As per Specification enclosed in Chapter - 4	1 Unit	To be picked from and delivered to NECTAR, Shillong, Meghalaya

B) Period of delivery shall start from : _____

C) Term of Delivery / Delivery Term (named port of shipment or named place of delivery):

Goods from India	
------------------	--

D) Scope of Supply:

.....
.....

E) Time frame required for conducting Fabrication, commissioning of the equipment, acceptance test, etc. after the arrival of consignment or before dispatch of equipment:

Sr. No.	Activity	Time Frame
1	Site Preparation (if required)	
2	Fabrication & Commissioning	
3	Acceptance Test / Inspection	

Place : _____

Signature of the Bidder : _____

Date : _____

Notes for Bidders:

(1)	The delivery schedule shall clearly indicate the time period within which the successful bidder must deliver the consignment in full from the date of acceptance of contract. etc. It should also indicate separately the time period desired for installation and commissioning of the equipment after arrival of the consignment at the premises of the Purchaser.
(2)	The date or period for delivery should be carefully specified, taking into account the implications of delivery terms stipulated in the Instructions to Bidders pursuant to the Incoterms rules (i.e., FCA/CIP terms—that “delivery” takes place when goods are delivered to the carriers), and the date prescribed herein from which the delivery obligations start (i.e., notice of award, contract signature, opening or confirmation of the letter of credit.

Chapter 4

Specifications and Allied Technical Details for Body Building of Mobile Processing Unit on Truck Chassis

4.1 End Use: Research and Development

Instrument Name : Body Building of Mobile Processing Unit on Truck Chassis

(Detailed specification, Chassis Details, place of work and drawing enclosed at Annexures)

(CHASIS TO BE PICKED FROM AND DELIVERED TO NECTAR, SHILLONG, MEGHALAYA AFTER COMPLITION OF FABRICATON WORK AS PER CONTRACT)

4.2 Scope of Fabrication works: Scope of Supply includes the following:

- I. Supply of the equipment / system along with the accessories.
- II. Fabrication, Commissioning and Acceptance by the end user
- ~~III. Training as specified in tender~~
- IV. On site comprehensive Warranty as specified in SCC
- ~~V. Annual Maintenance Contract / Maintenance Support as specified in BoQ~~
- VI. Delivery Schedule as specified in SCC

4.4.2 Manufacturer's Inspection Certificate

After the goods are fabricated and assembled, inspection and testing of the goods may be carried out at the supplier's facility by the supplier, prior to shipment to check whether the goods are in conformity with the technical specifications. Manufacturer's test certificate with data sheet shall be issued to this effect and submitted along with the delivery documents. The purchaser reserves the options to be present at the supplier's premises during such inspection and testing.

4.4.3 Installation, Commissioning and Acceptance Test

The acceptance test will be conducted by the Purchaser, their consultant or other such person nominated by the Purchaser at its option after the equipment is installed at Purchaser's site in the presence of supplier's representatives. The acceptance will involve trouble free operation. There shall not be any additional charges for carrying out acceptance test. No malfunction, partial or complete failure of any part of the equipment is expected to occur. The Supplier shall maintain necessary log in respect of the result of the test to establish to the satisfaction of the Purchaser, the successful completion of the test specified.

On the event of the ordered item failing to pass the acceptance test, a period not exceeding two weeks will be given to rectify the defects and clear the acceptance test, failing which, the Purchaser reserve the right to get the equipment replaced by the Supplier at no extra cost to the Purchaser.

Successful conduct and conclusion of the acceptance test for the installed goods and equipment shall also be the responsibility and at the cost of the Supplier.

The acceptance tests at the final destination include the following:

a)	
b)	

4.5 Training: NA

1)	Location	
2)	Number of persons	
3)	Period of Training	
4)	Nature of Training	

CHAPTER-5

Price Schedule forms

Bidder Should quote as per the BOQ Format Only as uploaded in <https://etenders.gov.in> along with Tender documents

CSIR-CFTRI is a Public Funded Research Institute under Department of Scientific & Industrial Research, Government of India and concessional Custom duty @ 0/5.15% is applicable for the goods purchased for Research purpose vide Government of India vide Notification No.51/96–Customs dated 23-July-1996, as amended from time to time.

CSIR-CFTRI is not eligible to issue any GST concessional rate certificate. Hence, bidder may submit their bid accordingly.

CHAPTER-6

Qualification Requirements

6.1 Eligibility Criteria

a) Legal Valid Entity:

The Bidder shall necessarily be a legally valid entity either in the form of a Limited Company or a Private Limited Company registered under the Indian Companies Act, 1956 or as per rules prevailing in the country of origin/shipment

Bidder may be Joint Venture, Consortium or Association so long as they are formed and registered prior to the bid submission date.

Copy of Certificate of Incorporation issued by Registrar of firms/companies is to be submitted in support of this criterion or as per rules prevailing in the country of origin/shipment

b) In case of Global Tender Enquiry, Indian Agent quoting on behalf of Foreign Principal Supplier should submit a certified copy of an Agreement/Memorandum of understanding (MOU) between both the parties, detailing services to be rendered by the Agency.

c) An undertaking (self-certificate) is to be submitted to demonstrate that the bidder satisfies the bidders' eligibility criteria, as mentioned in ITB Clause 1.1.2 in the form of declaration by the Bidder for Code of Integrity & conflict of interest as per **Chapter-8: Annexure-L**.

d) Declaration by the bidder on letter head that he has not been disqualified or black listed or suspended by any other lab of CSIR or any other Govt. Organization/Govt. of India establishment or suspended by CPPP or GeM portals, in the past 24 months.

6.2 Technical Qualification Criteria

Criteria 1 - Experience and Past Performance:

- a) The bidder (manufacturer or principal of authorised representative – hereinafter referred simply as 'The Bidder') should have regularly for at least the last_3 years, ending 31st March of the previous financial year (hereinafter called 'The relevant Date'), manufactured and supplied (/erected/ commissioned with the same or higher specifications having/with parameters (herein after called 'The Product'). The bidder should submit the manufacturer authorisation form as appended in Chapter-8 and
- b) 'The bidder' should have Fabricated and supplied similar kind of items at least **TWO** numbers (herein after referred as 'The Qualifying Quantity') of 'The Product' in at least one of the last three years ending on 'The relevant Date.'

Criteria 2 - Capability- Equipment & manufacturing Facilities: -NA

'The bidder' must have an annual capacity to manufacture and supply (/erected/ commissioned) at least NA (The Qualifying Quantity)

Note: In case of multiple products in a tender, this criterion shall be applicable product wise. For example, in case of Printing Paper of different specifications/sizes, it shall be applicable to quantity of paper manufactured and supplied specification/size wise.

6.3 Financial Qualification Criteria

- ~~a) The average annual financial turnover of 'The bidder' during the last three years, ending on 'The relevant Date', should be at ₹.....NA..... as per the annual report (audited balance sheet and profit & loss account) of the relevant period.~~
- ~~b) A copy of the annual report (audited balance sheet and profit & loss account) of the relevant period, duly authenticated by a Chartered Accountant/Cost Accountant in India or equivalent in relevant countries, is to be submitted in support of this criterion. NA~~
- ~~c) The net worth of the Bidder firm (manufacturer or principal of authorized representative) should not be negative on 'The Relevant Date' and also ii) should have not eroded by more than 30% (thirty percent) in the last three years, ending on 'The Relevant Date' (31-03-2023). Self-declaration on letterhead of the company to be provided in support of this. (Documentary evidence or supporting document).~~

Note: In case of Indian Bidders/companies (manufacturer or principal of authorized representative) who have been restructured by Banks in India, under the statutory guidelines, they would be deemed to have qualified the Financial standing criteria considering the institutional financial backing available to them.

Applicability in Special Cases:

- a) **Applicability to 'Make in India':**
Bidders (manufacturer or principal of authorised representative) who have a valid/approved ongoing 'Make in India' agreement/ program and who while meeting all other criteria above, except for any or more of sub-criteria in Experience and Past Performance above, would also be considered to be qualified provided:

i)	their foreign 'Make-in-India' associates meet all the criteria above without exemption, and
ii)	the Bidder submits appropriate documentary proof for a valid/approved ongoing 'Make in India' agreement/program.
iii)	the bidder (manufacturer or principal of authorised representative) furnishes along with the bid a legally enforceable undertaking jointly executed by themselves and such foreign Manufacturer for satisfactory manufacturing, Supply (and erection, commissioning if applicable) and performance of 'The Product' offered including all warranty obligations as per the general and special conditions of contract.

- b) **Authorized Representatives:**
Bids of bidders quoting as authorised representative of a principal manufacturer would also be considered to be qualified, provided:

i)	their principal manufacturer meets all the criteria above without exemption, and
ii)	the principal manufacturer furnishes a legally enforceable tender-specific authorisation in the prescribed form assuring full guarantee and warranty obligations as per the general and special conditions of contract; and
iii)	the bidder him self should have been associated, as authorised representative of the same or other Principal Manufacturer for same set of services as in present bid (supply, installation, satisfactorily commissioning, after sales service as the case may be) for same or similar 'Product' for past three years ending on 'The Relevant Date'.

c) **Joint Ventures and Holding Companies:**

Credentials of the partners of Joint ventures cannot be clubbed for the purpose of compliance of PQC in supply of Goods/Equipment, and each partner must comply with all the PQC criteria independently. However, for the purpose of qualifying the Financial Standing Criteria, the Financial Standing credentials of a Holding Company can be clubbed with only one of the fully owned subsidiary bidding company, with appropriate legal documents proving such ownership.

Note for Bidders:

a) **'Doctrine of Substantial Compliance':**

The Pre-Qualification Bidding (PQB) and Pre-Qualification Criteria (PQC) are for shortlisting of sources who are competent to perform this contract to ensure best value for money from expenditure of Public Money. This process is neither intended to bestow any entitlement upon nor to create any rights or privileges for the Bidders, by way of overly hair-splitting or viciously legalistic interpretations of these criteria, disregarding the very rationale of the PQB and PQC. Keeping this caveat in view, interpretation by the Purchaser would be based on common usage of terminologies and phrases in public procurement in accordance with the 'Doctrine of Substantial Compliance' and would be final.

b) The Bidder must declare, whether asked or not in a bid document, any previous transgressions of such a code of integrity with any entity in any country during the last three years or of being debarred by any other Procuring Entity. Failure to do so would amount to violation of this code of integrity.

c) In case of agents quoting in offshore procurements, on behalf of their principal manufacturers, one agent cannot represent two manufacturers or quote on their behalf in a particular tender enquiry. One manufacturer can also authorize only one agent/ dealer. There can be only one bid from the following:

i)	The Principal manufacturer directly or through one Indian agent on his behalf; and
ii)	Indian/foreign agent on behalf of only one principal.

d) Along with all the necessary documents/certificates required as per the tender conditions, the bidder should furnish a brief write-up, backed with adequate data, explaining their available capacity (both technical and financial), for manufacture and supply of the required goods/equipment, within the specified time of completion, after meeting all their current commitments.

e) Supporting documents submitted by the bidder must be certified as follows:

i)	All copy of supply/work order; respective completion certificate and contact details of clients; documents issued by the relevant Industries Department/National Small Industries Corporation (NSIC)/ manufacturing license; annual report, etc., in support of experience, past performance and capacity/capability should be authenticated by the by the person authorised to sign the tender on behalf of the bidder. Original Documents must be submitted for inspection, if so demanded.
ii)	All financial standing data should be certified by certified accountants, for example, Chartered Accountants/Cost Accountants or equivalent in relevant countries; and Indian bidder or Indian counterparts of foreign bidders should furnish their Permanent Account Number.

f) A bidder or any of its affiliates who participated as a consultant in the preparation of the design or technical specifications of the contract i.e. the subject of the bid; cannot participate in the bidding process.

g) Indian agents quoting on behalf of its foreign principal need to submit a copy of the agency agreement with the foreign principal detailing the services to be rendered by them on behalf of the principals, failing which the bid shall not be considered.

h) Foreign bidders to disclose the name and address of agent and representatives in India and Indian bidder to disclose their foreign principal or associates.

CHAPTER 7

Contract Form

For details kindly refer Standard Tender Documents uploaded at CSIR-CFTRI website i.e. www.cftri.res.in →Tender

CHAPTER 8

Other Standard Forms (To be enclosed as indicated below)

TABLE OF CONTENTS

Sl. No.	Name	Annexure
1	Bid Security Form (to be enclosed with the technical bid)	A
2	Bid Securing Declaration. (to be enclosed with the technical bid)	B
3	Bidder Information Form (to be enclosed with the technical bid)	C
4	Bid Form	D
5	Manufacturers Authorization Form (to be enclosed with the technical bid)	E
6	Performance Statement Form (to be enclosed with the technical bid)	F
7	Service Support Detail Form (to be enclosed with the technical bid)	G
8	Certificate of Local Content with Percentage	I & J
9	Self-Certification (to be enclosed with technical bid)	L
10	Deviation Statement Form (to be enclosed with the technical bid)	M
11	Performance Security Form (to be submitted on award of Contract)	N
12	Acceptance Certificate Form (to be submitted on award of Contract)	O
13	Check List	

Note: Please refer clause 1.10.1 of the bidding documents for other documents to be attached with the bids/offers

For details kindly refer Standard Tender Documents uploaded at CSIR-CFTRI website i.e. www.cftri.res.in→Tender

The Terms and conditions of Standard Tender Documents uploaded at CSIR-CFTRI website i.e. www.cftri.res.in→Tender is integral part of this tender.

CHAPTER-9

Check List

Tender No.	CFTRI/82417/2023	
Sr. No.		
1	Indian Customs Tariff No. and HSN No. (ICT & HSN No.)	
2	Country of Origin	
3	Type of Supplier	
4	Mode of Shipment	
5	Delivery Term (INCO Term), as the case may be	
6	Delivery Schedule including Fabrication, Commissioning, Training & Acceptance	
a)	Delivery of the Item as per Chapter-4/BoQ [In weeks / Days / Months] from the date of PO	
b)	Installation & Commissioning from the date of Delivery of item [In weeks/Days/Months]	
c)	Training from the date of Installation & Commissioning of item [In weeks/Days/Months]	
d)	Acceptance from the date of Training [In weeks/Days/Months]	
7	Installation & Commissioning (if any) Quoted Price inclusive	
8	Training (if any) at site Quoted Price inclusive	

9	Payment Term	
10	Currency of Bid/Quotation	
11	Statutory Levies [GST/IGST or any other taxes, duties] % of tax to be mentioned.	
12	Bidder GST No.	
13	Bidder Bank Details along with Cancelled cheque	
14	Insurance Coverage as per GCC/SCC Clause No.2.17.1	
15	Warranty	
16	Agree to submit Performance Security as per GCC/SCC Clause No.2.13.1	
17	Validity of offer as per Tender document	
18	Order to be placed [Full address, Tel #, Fax #, Email Id, Contact Person]	
19	Any other	
20	Total Price quoted as per BoQ/Price Schedule/List of Deliverables inclusive of tax	(Yes/No)
21	Certificate of Local Contents with Percentage (Annexure I & J)	
22	Self-declaration (Annexure-L), if country of Origin is Foreign, Bidders may provide the details, as per GOI Procurement Policies (DIPP Order No.P-45021/2/2017-PP (BE-II).	

Annexures for SPECIFICATIONS and Nature of Work

ANNEXURE-A

BODY BUILDING OF MOBILE PROCESSING UNIT FOR FRUITS AND VEGETABLES IN NORTH EAST

CSIR - Central Food Technological Research Institute, Mysuru is working on development of *Mobile Processing Unit for Fruits and Vegetables Processing* to showcase processing techniques to farmers (on-site) and encourage them to take up value addition, by converting raw materials into semi-finished or finished products, particularly during excess production. The scope of work includes body building on a vehicle Chassis with Cowl (TATA LPT1923 48 Truck) provided by CSIR-CFTRI for which detailed specifications are given in Annexure 1.

For body building of Mobile Processing unit, the Chassis has to be picked from “North East Centre for Technology Application & Reach (NECTAR), Survey of India Campus, Bonnie Brae Estate, Barik Point, Shilong, Meghalaya- 793001 and unit to be delivered at the same place on completion of the work.

The Mobile Demonstration Unit should be versatile enough to replace the equipments with others to suit the requirements of individual processing lines to handle different commodities. The conceptual layout drawing is provided in Annexure-2. The mobile unit should have 2 major sections namely, Cabin and Equipment section.

Payload: 6 to 8 MT GVW

: 18.5 MT

Overall dimension of the size should be as per Government Norms (RTO) CHASSIS:

Chassis should be provided with suitable cross section and other structural supports to withstand a payload of at least 6 MT (Equipment mounting). The overall vehicle size to be as per RTO guidelines. Stainless Steel plates of suitable thickness and grade to be provided on the top surface of mounting bracket to place the equipment.

EQUIPMENT SECTION:

The equipment section will have different processing equipment (supplied by CFTRI) mounted on the support structure provided on chassis. The fixing arrangement should be such that equipment can be replaced with others to accommodate

different processing line. However, the fixture should be firm enough to withstand all forces acting during transport or operation. As water is extensively used, provision should be made for quick draining of water from this section. And, the floor in this section shall be non-slippery.

The sides of rear wall of equipment section to be of flip open type, top portion to have lever and hinge system open up with suitable locking systems, while the bottom portion should have support at the bottom with necessary height adjustment mechanism and collapsible railing all around (as indicated in 3D image attached, Annexure 2). The sheet provided to the wall on bottom side to be strong enough to withstand the load of people standing (approx. 600 – 700kg) on them during working. The metal frame structure to be of SS or any other rust free material, outer sheet to be aluminum and inner portion to be AISI 304. The outer sheet of walls to be compatible for graphic work and also withstand environmental conditions (heat, rain, wind etc.). The metal joints to be minimized/sealed to prevent accumulation of food particles, dust and growth of microbes.

Suitable Mounting brackets of AISI 304 for placing Diesel Generator and different types of equipment in two rows to be provided in the equipment area.

Electrical conduits and wires to be provided (concealed) to all equipment points and be connected to a central panel in equipment section. Total installed load is approximately 70-80 kW (1ph/3ph). All safety features to be built-in, to take care of electrical safety and fire emergency. All equipments to be provided with individual control switches/indicators. Fire extinguisher mountings and first aid kit box to be provided. Water line to be provided in the equipment section with water connection points/taps and line to be connected to water tank (500 L, Stainless Steel, rectangular with shorter height) to be provided on the top of the vehicle.

Change over provision should be made to provide power supply either from DG or external source.

Electrical Boards at equipment places should be provided.

Power supply for Fridge/Cooler and light to be provided from engine.

The equipment section to be illuminated with LED bulbs, additional 4-6 electrical power points (15A/5A) to connect gadgets like computer, LED monitors,

Mixer/Grinder, Refrigerator, Freezer, etc., to be provided. Flexible belt system (3-4 nos.) to secure safety of above gadgets during movement of vehicle to be provided.

To be provided with foldable AISI 304 tables (2 nos., 3x1.5 feet) and, sink with tap and drain

CABIN:

The cabin to be built with premier quality material in standard way with driver/co- passenger seat and sleeper berth facility. Sliding door and wide viewing window to view equipment area is to be provided. It should have all other general facilities like audio system, storage boxes, etc. Door to be provided for movement between cabin and equipment area. Cabin area must have AC facility with suitable controls.

Detailed design drawings and 3D views of mobile unit to be prepared and approval need to be taken from CSIR-CFTRI before commencing the body building work.

The interested firm(s) can visit CSIR-CFTRI, Mysuru, to see the Mobile Food Processing and Demonstration unit developed by the Institute, in order to have any further clarity on body building.

Annexure 1

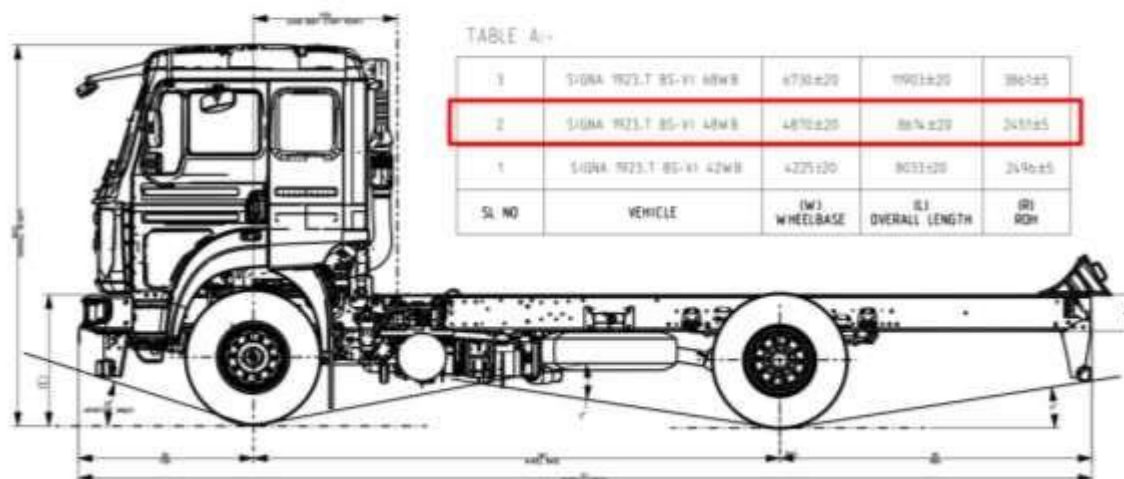

Chassis Transmission System	Manual
Max Engine Power BHP	221
Max Engine Torque (N-m)	925
Engine Aspiration	Turbocharged Intercooled
No of Cylinder in Engine (Nos)	6
Ground Clearance (mm)	230 millimeter
Wheel Base (mm)	4855 millimeter
Kerb Weight (Kg)	4800 kilogram
Gross Vehicle Weight (Kg)	18500 kilogram
Type of Steering	Power
No of Axle (Nos)	2
Axle Configuration (No of Outside Tyre x No of Driving Tyre)	4x2
Type of Front Axle and Suspension System	Extra Heavy Duty Forged I Beam Reverse Elliot Type & Semi Elliptic Multi Leaf Spring
Type of Rear Axle and Suspension System	Single Reduction, Hypoid Gears, Fully Floating Axle & Semi Elliptic Multi Leaf Spring
No of Speed/ Forward Gears (Nos)	6

CONSTRUCTION	
Design of Chassis	Full Frame chassis
Body Options	Customise-able
Fuel Tank Capacity (Ltrs)	365
Length of Chassis (mm)	8325
Width of Chassis (mm)	1950
Height of Chassis (mm)	2440
Gradeability of Chassis(%) (%)	19
Type of Vehicle Tyre	Radial
Size Of Front Tyres	295/90R20 2 Qty
 Ask GeMmy	295/90R20 4 Qty

Annexure 2 Mobile Processing Unit

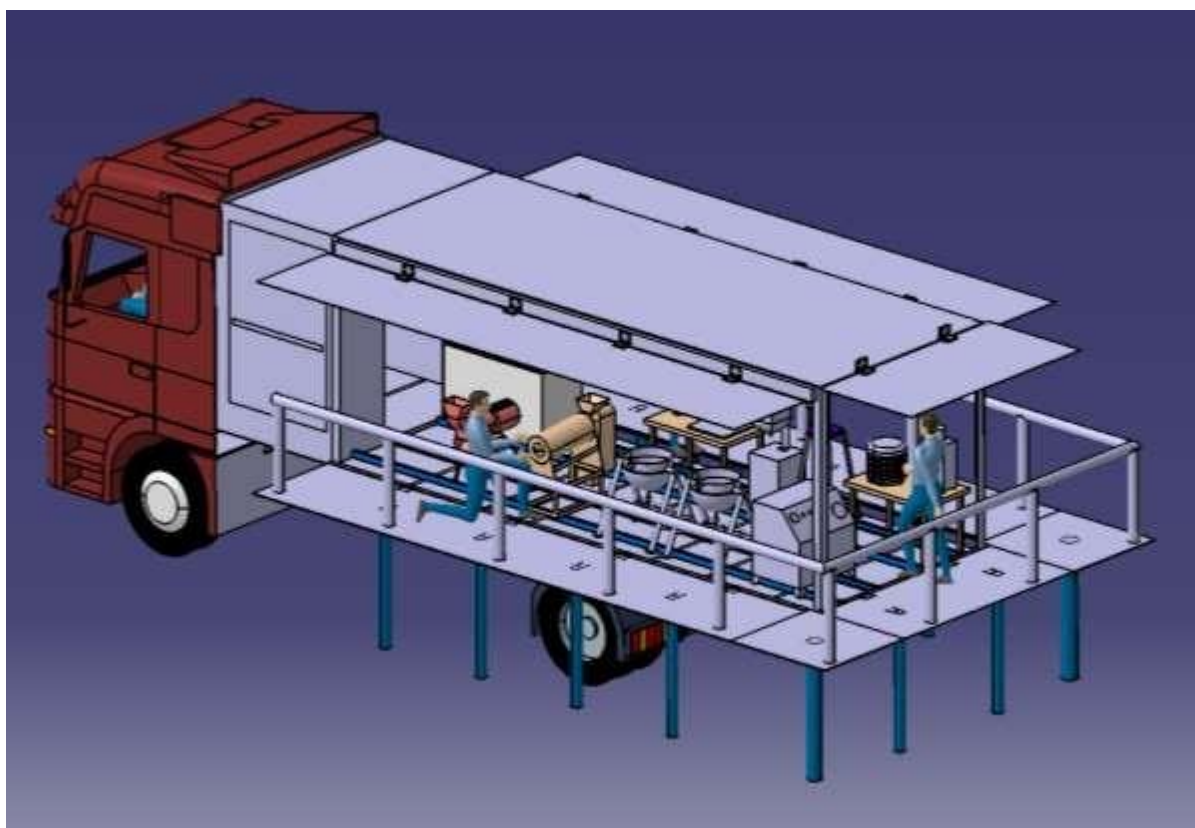

Annexure -3

Equipment mounting detail

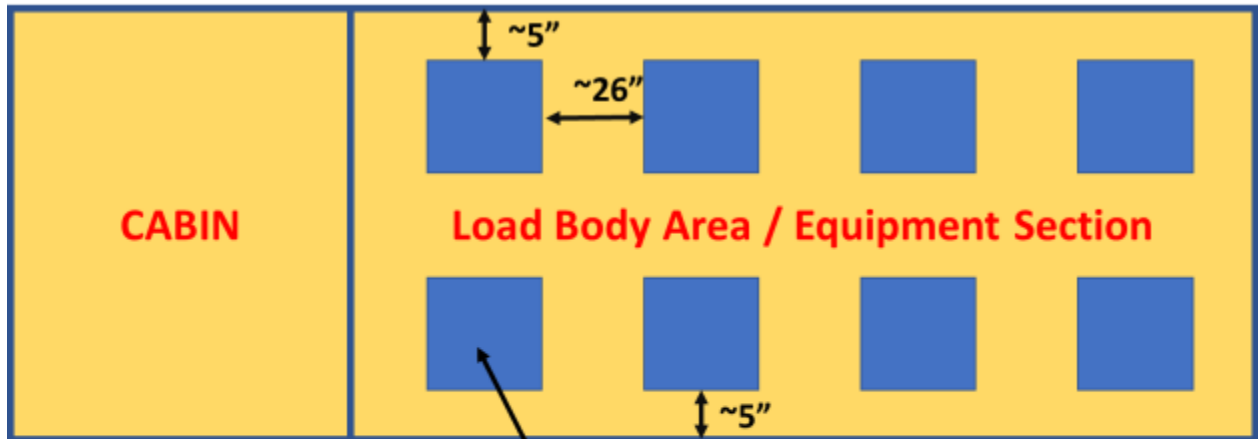

Equipment Mounting Plates
Size: 31" X 31"
Material: SS 304
Thickness: Minimum 6 mm

- These Equipment mounting plates should be bolted to suitable mounting bracket.
- The mounting bracket should be strong enough to bear the equipment load of minimum 500 kg, fixed firmly on load body area and its height should be sufficient enough (~5") for assembling and dis-assembling the equipment.